

Non-linear Optics I

(Electro-optics)

P.E.G. Baird
MT2011

Domain of Linear Optics

From electromagnetism courses we recall

$$\mathbf{D} = \varepsilon_0 \varepsilon_r \mathbf{E} = \varepsilon_0 \mathbf{E} + \mathbf{P} = \varepsilon_0 \mathbf{E} (1 + \chi) \quad (1)$$

Also at optical frequencies,

$$n = \sqrt{\varepsilon_r} = (1 + \chi)^{1/2} \sim 1 + \frac{1}{2}\chi \dots \quad (2)$$

$$P_i = \varepsilon_0 \sum \chi_{ij} E_j \quad (3)$$

The medium may not be isotropic and homogeneous; the polarisation P will not in general be collinear with E , and the susceptibility $\chi^{(n)}$ and the permittivity $\bar{\varepsilon}$ are tensors (in this case of rank 2)

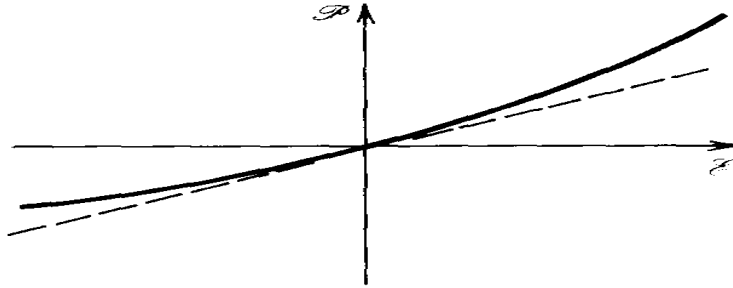

Figure 1: Linear versus nonlinear electric field effects

Domain of Non-linear Optics

$$P(\omega) = \varepsilon_0 \sum [\chi_{ij}^{(1)} E_j(\omega_1) + \chi_{ijk}^{(2)} E_j(\omega_1) E_k(\omega_2) + \chi_{ijkl}^{(3)} E_j(\omega_1) E_k(\omega_2) E_l(\omega_3) \dots] \quad (4)$$

Typical values for the second order coefficient $d = \chi^{(2)}/2\varepsilon_0 = 10^{-24}$ to 10^{-21} AsV⁻². Typical values for the third order non-linear susceptibility $\chi^{(3)}$ is 10^{-29} to 10^{-34} (MKS units) for glasses, crystals, semiconductors and organics materials of interest. Only crystals with *NO* centre of symmetry¹ have a finite second order susceptibility; for other materials the first non-linear coefficient is $\chi^{(3)}$

¹ If a crystal possesses inversion symmetry the application of an electric field E along some direction causes a change $\Delta n = sE$ in the index. If the direction of the field is reversed the change becomes $\Delta n = s[-E]$, but inversion symmetry requires the two directions to be physically equivalent. This requires $s = -s$ which is possible only for $s = 0$. Thus, linear, Pockels crystals require *NO* centre of symmetry. Note also that these crystal are piezo-electric.

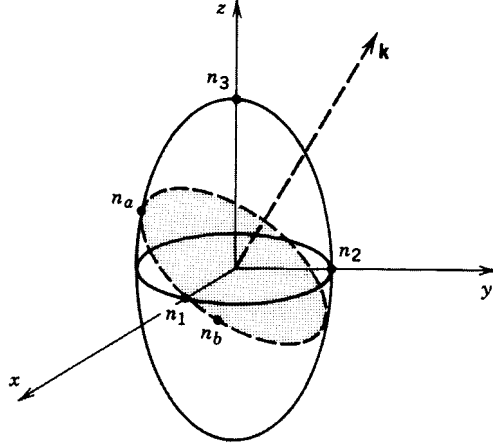

Figure 2: Index ellipsoid

Index Ellipsoid for a Uniaxial System

The optical properties of an anisotropic medium can be characterised by a geometric construction called the index ellipsoid where $\bar{\bar{\eta}}$ is the so-called impermeability tensor related to the refractive index as given above. The principal axes of the ellipse are the optical principal axes; the principal dimensions along these axes are the principal refractive indices: n_1, n_2, n_3 . (Note also that the phase velocity of the wave is proportional to $1/n$). *Uniaxial* means $n_x = n_y \neq n_z$ (the optical axis). See appendix.

$$\frac{x^2 + y^2}{n_o^2} + \frac{z^2}{n_e^2} = 1 \quad (5)$$

Thus for an arbitrary angle θ to the z -axis as shown,

$$n(\theta) = \left\{ \frac{\cos^2 \theta}{n_o^2} + \frac{\sin^2 \theta}{n_e^2} \right\}^{-1/2} \quad (6)$$

Linear Electro-optic Effect (Pockels).

When a steady electric field E with components (E_1, E_2, E_3) is applied to the crystal the elements of the tensor $\bar{\bar{\eta}}$ are altered so that each of the 9 elements becomes a function of E and the ellipsoid changes shape. Thus, in equation 4 we let $E_k(\omega_2) = E^0$ - a d.c. electric field so that,

$$P(\omega) = \varepsilon_0 [\chi_{ij}^{(1)} + \chi_{ijk}^{(2)} E^0] E(\omega) \quad (7)$$

Since χ is related to ϵ , the equation can be re-written in terms of the refractive index where each of the elements $\eta_{ij}(E)$, is a function of the appropriate field components, i.e.

$$\eta_{ij}(E) = \varepsilon_0 / \varepsilon = 1/n^2 = \eta_{ij} + \sum_k r_{ijk} E_k + \sum_{k,l} s_{ijkl} E_k E_l \dots\dots$$

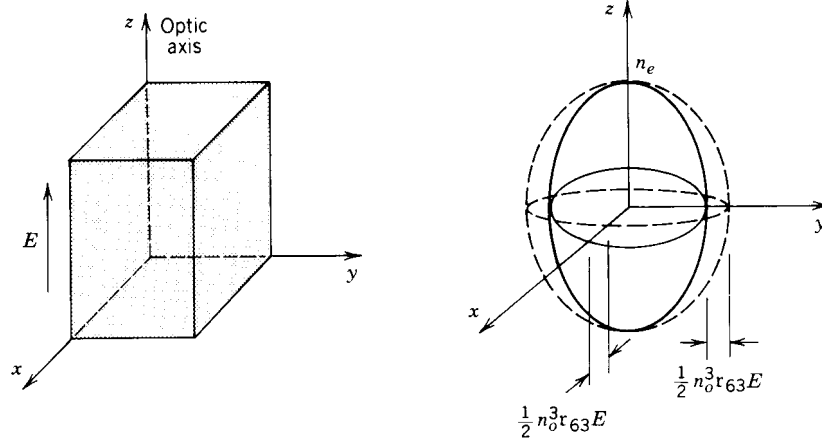

Figure 3: Index ellipsoid for a $\bar{4}2m$ crystal

Terms linear in the applied field represent the Pockels effect; those quadratic in E represent the Kerr effect. Alternatively, we could write, by Taylor expansion,² the refractive index in the presence of an electric field as follows,

$$n(E) = n_0 + a_1 E + \frac{1}{2} a_2 E^2 \dots$$

This introduces the connection between the linear electro-optic coefficients and the polarisation of the medium, see equation (9).

Linear Electro-optic Tensor

The change to the index ellipsoid when an electric field is applied can be written as follows,

$$\frac{x^2}{n_1^2} + \frac{y^2}{n_2^2} + \frac{z^2}{n_3^2} + \frac{2yz}{n_4^2} + \frac{2xz}{n_5^2} + \frac{2xy}{n_6^2} = 1 \quad (8)$$

Clearly if the indices 1, 2, 3,...are chosen to be coincident with the principal dielectric axes equation 8 must reduce to equation 5 in the absence of the electric field, *i.e.* that $1/n_{4,5,6} = 0$

This introduces the linear electro-optic tensor r^{LEO}

$$\Delta \left(\frac{1}{n^2} \right) = \sum r_{ijk} E_k^0 \quad (9)$$

This is a $3 \times 3 \times 3$ matrix, *i.e.*, it has 27 elements. Of these, physical symmetry reduces the number to 18 independent elements, written as a 3×6 matrix. [$r_{ijk} = \partial \eta_{ij} / \partial E_k$ where $\eta = \varepsilon_0 \varepsilon^{-1}$ and the index ellipsoid is given by $\sum \eta_{ij} x_i x_j = 1$ where $i, j = 1, 2, 3$ with principal indices of refraction n_1, n_2, n_3 (see footnote 2) and η is symmetric with respect to interchange of indices i, j . Thus, it follows r (and d) are also invariant under i, j interchange. It is therefore conventional to reduce the i, j index to one symbol I with the correspondence as given in the “look up” table 1]

² By Taylor expanding the refractive index about $E = 0$ we can write

$$n(E) = n_0 + a_1 E + \frac{1}{2} a_2 E^2 \dots$$

where the coefficients are derivatives of the refractive index with E in the normal way. Defining $r = -2a_1/n^3$ and $s = -a_2/n^3$ we have for $\eta = \varepsilon_0/\varepsilon = 1/n^2$ the following field dependent change $\Delta \eta = (d\eta/dn) \Delta n = (-2/n^3)(-\frac{1}{2} r n^3 E - \frac{1}{2} s n^3 E^2 \dots)$.

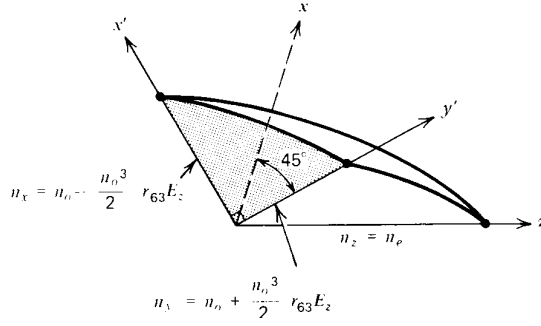

Figure 4: Rotation of axes by 45° about the optical axis.

$j \downarrow i \rightarrow$	1	2	3
1	1	6	5
2	6	2	4
3	5	4	3

Table 1 Look up table for $i, j \rightarrow I$

Any particular Pockels crystal will further reduce the number of non-zero elements as follows. As an example, consider the uniaxial crystal ADP (ammonium dihydrogen phosphate) which has tetragonal ($\bar{4}2m$) symmetry. The index ellipsoid (see figure 3) is represented by

$$\begin{bmatrix} \Delta \left(\frac{1}{n^2} \right)_1 \\ \Delta \left(\frac{1}{n^2} \right)_2 \\ \Delta \left(\frac{1}{n^2} \right)_3 \\ \Delta \left(\frac{1}{n^2} \right)_4 \\ \Delta \left(\frac{1}{n^2} \right)_5 \\ \Delta \left(\frac{1}{n^2} \right)_6 \end{bmatrix} = \begin{bmatrix} 0 & 0 & 0 \\ 0 & 0 & 0 \\ 0 & 0 & 0 \\ r_{41} & 0 & 0 \\ 0 & r_{52} & 0 \\ 0 & 0 & r_{63} \end{bmatrix} \begin{bmatrix} E_1^0 \\ E_2^0 \\ E_3^0 \end{bmatrix} \quad (10)$$

The crystal is now *biaxial*.

Or in terms of the polarisation of the medium³, which we shall use for optical fields in harmonic generation,

$$\begin{bmatrix} P_x \\ P_y \\ P_z \end{bmatrix} = \epsilon_0 \begin{bmatrix} 0 & 0 & 0 & d_{14} & 0 & 0 \\ 0 & 0 & 0 & 0 & d_{25} & 0 \\ 0 & 0 & 0 & 0 & 0 & d_{36} \end{bmatrix} \begin{bmatrix} E_x^2 \\ E_y^2 \\ E_z^2 \\ 2E_y E_z \\ 2E_x E_z \\ 2E_x E_y \end{bmatrix} \quad (11)$$

If we take as the direction of the applied d.c. field $E^0 = E_z^0 = E_3^0$ then the new index ellipsoid will given by

$$\frac{x^2}{n_o^2} + \frac{y^2}{n_o^2} + \frac{z^2}{n_e^2} + 2r_{63}xyE_z^0 = 1 \quad (12)$$

³ The coefficients d and r are related as follows: $d = \frac{\epsilon_0 \chi^{(2)}}{2}$ and $r \sim -\frac{4d}{\epsilon_0 n^4}$. Be careful about factors of 2 arising from the use of a complex field. For the Pockels case let the d.c. and optical fields be represented as $E(t) = E^0 + \text{Re}\{E(\omega) \exp(-i\omega t)\}$. For the case of H.G. let the coupled optical fields be represented as $E(t) = \text{Re}\{E(\omega_1) \exp(-i\omega_1 t) + E(\omega_2) \exp(-i\omega_2 t)\}$.

For S.H.G. in particular let $\omega_1 = \omega_2$

$$()6 = xy + yx = 2xy$$

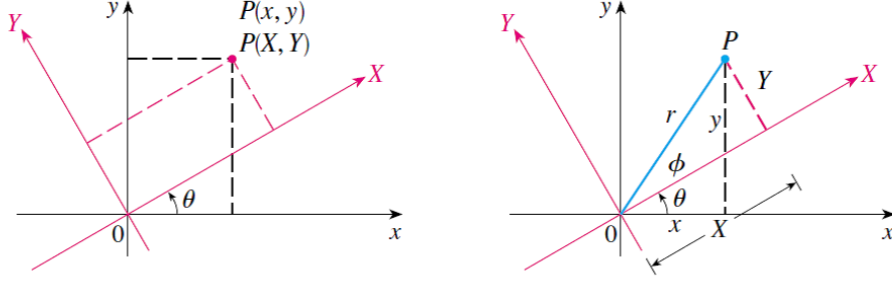

Figure 5: Rotation of Axes

A clockwise rotation take axes XY onto xy :(Equivalently a positive angle to the positive x-axis amounts to an anticlockwise rotation). The relationship between the different co-ordinate systems for a 45° rotation is given by simple trigonometry as follows

$$\begin{pmatrix} x \\ y \end{pmatrix} = \frac{1}{\sqrt{2}} \begin{pmatrix} 1 & -1 \\ 1 & 1 \end{pmatrix} \begin{pmatrix} X \\ Y \end{pmatrix} \quad (13)$$

or,

$$\begin{pmatrix} X \\ Y \end{pmatrix} = \frac{1}{\sqrt{2}} \begin{pmatrix} 1 & 1 \\ -1 & 1 \end{pmatrix} \begin{pmatrix} x \\ y \end{pmatrix} \quad (14)$$

In the present case x, y represent the original axes which are transformed to x', y' ($\equiv X, Y$ in the figure) by an anticlockwise rotation. Thus inserting.

$$x = 1/\sqrt{2}(x' - y') \quad \text{and} \quad y = 1/\sqrt{2}(x' + y') \quad (15)$$

into the equation for the ellipsoid 12 we have

$$\frac{(x' - y')^2}{2n_o^2} + \frac{(x' + y')^2}{2n_o^2} + \frac{2(x' - y')(x' + y')}{2} r_{63} E_z^0 + \frac{z^2}{n_e^2} = 1 \quad (16)$$

which when rearranged gives

$$\frac{x'^2}{n_o^2} + \frac{y'^2}{n_o^2} + (x'^2 - y'^2) r_{63} E_z^0 + \frac{z^2}{n_e^2} = 1 \quad (17)$$

leading to

$$\frac{x'^2}{n_o^2} (1 + n_o^2 r_{63} E_z^0) + \frac{y'^2}{n_o^2} (1 - n_o^2 r_{63} E_z^0) + \frac{z^2}{n_e^2} = 1 \quad (18)$$

This identifies

$$\frac{1}{n_{x'}^2} = \frac{(1 + n_o^2 r_{63} E_z^0)}{n_o^2} \quad (19)$$

Or equivalently

$$n_{x'}^2 = \frac{n_o^2}{(1 + n_o^2 r_{63} E_z^0)} \quad (20)$$

E_z , should be horizontal, not vertical

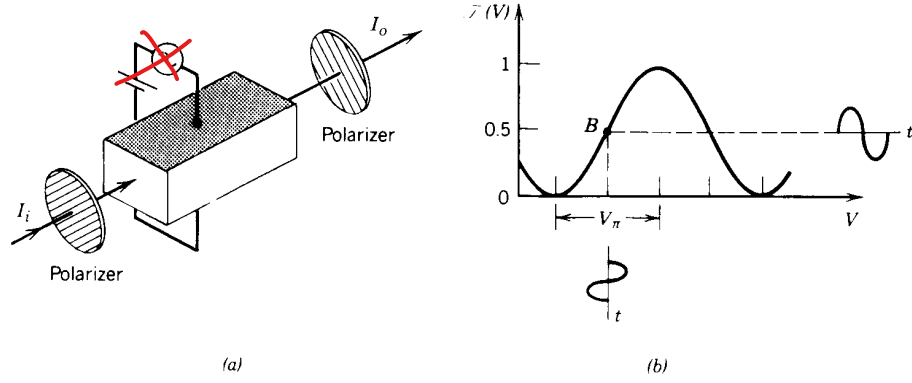

Figure 6: Electro-optic modulator used as an intensity modulator.

Thus, given that $r_{63}E_z^0 \ll n_o^{-2}$ we have $n_{x'} = n_0(1 + n_0^2 r_{63}E_z^0)^{-1/2} \sim n_0(1 - \frac{1}{2}n_0^2 r_{63}E_z^0)$ and similarly for $n_{y'}$. This gives finally

$$\Delta n = |n_{x'} - n_{y'}| = n_0^3 r_{63} E_z^0 \quad (21)$$

To act as a half-wave plate the phase induced by the field must be π radians, so

$$\phi = \frac{2\pi}{\lambda} \Delta n d = \pi \quad (22)$$

and the half-wave voltage is

$$V_\pi = \frac{\lambda}{2n_0^3 r_{63}} \quad (23)$$

Appendix

Wave-vector surface

Linear but tensorial χ

$$\begin{bmatrix} P_x \\ P_y \\ P_z \end{bmatrix} = \varepsilon_0 \begin{bmatrix} \chi_{11} & \chi_{12} & \chi_{13} \\ \chi_{21} & \chi_{22} & \chi_{23} \\ \chi_{31} & \chi_{32} & \chi_{33} \end{bmatrix} \begin{bmatrix} E_x \\ E_y \\ E_z \end{bmatrix} \quad (24)$$

The wave equation including polarisation but not conduction currents J is of the form

$$\nabla \times (\nabla \times \mathbf{E}) + \frac{1}{c^2} \frac{\partial^2 \mathbf{E}}{\partial t^2} = -\frac{1}{c^2} \boldsymbol{\chi} \frac{\partial^2 \mathbf{E}}{\partial t^2} \quad (25)$$

The transparent, insulating crystal can thus sustain a plane monochromatic wave ($E_0 \exp i\{\mathbf{k} \cdot \mathbf{r} - \omega t\}$) provided the propagation vector satisfies the equation

$$\mathbf{k} \times (\mathbf{k} \times \mathbf{E}) + \frac{\omega^2}{c^2} \mathbf{E} = -\frac{\omega^2}{c^2} \boldsymbol{\chi} \mathbf{E} \quad (26)$$

The cartesian components of this equation are thus

$$\left(-k_y^2 - k_z^2 + \frac{\omega^2}{c^2} \right) E_x + k_x k_y E_y + k_x k_z E_z = -\frac{\omega^2}{c^2} \chi_{11} E_x \quad (27)$$

and similarly for y - and z - components.

To interpret this result let the wave propagate along one of the principal axes of the crystal, say z . In this case $k_z = k$ and $k_x = k_y = 0$ and the components become

$$\left(-k^2 + \frac{\omega^2}{c^2} \right) E_x = -\frac{\omega^2}{c^2} \chi_{11} E_x \quad (28)$$

$$\left(-k^2 + \frac{\omega^2}{c^2} \right) E_y = -\frac{\omega^2}{c^2} \chi_{22} E_y \quad (29)$$

$$\frac{\omega^2}{c^2} E_z = -\frac{\omega^2}{c^2} \chi_{33} E_z \quad (30)$$

The last equation suggests $E_z = 0$ because neither χ or ω is zero. The wave is transverse. On the other hand, the first two equations show

$$k = \frac{\omega}{c} \sqrt{1 + \chi_{11}} = \frac{\omega}{c} \sqrt{K_{11}} = \frac{\omega}{c} n_1 \quad (31)$$

$$k = \frac{\omega}{c} \sqrt{1 + \chi_{22}} = \frac{\omega}{c} \sqrt{K_{22}} = \frac{\omega}{c} n_2 \quad (32)$$

where n_1 , n_2 and n_3 are the principal indices of refraction.

Now the equations for the components [27] lead to the following condition for non-trivial solution for the field components not to vanish, *i.e.*

$$\begin{vmatrix} \left(\frac{n_1 \omega}{c} \right)^2 - k_y^2 - k_z^2 & k_x k_y & k_x k_z \\ k_y k_x & \left(\frac{n_2 \omega}{c} \right)^2 - k_x^2 - k_z^2 & k_y k_z \\ k_z k_x & k_z k_y & \left(\frac{n_3 \omega}{c} \right)^2 - k_x^2 - k_y^2 \end{vmatrix} = 0 \quad (33)$$

This equation gives the wave-vector surface for propagation in the crystal. Thus, for example in the $k_z = 0$ plane the determinant gives a product of two factors either or both of which must reduce to zero. This condition gives

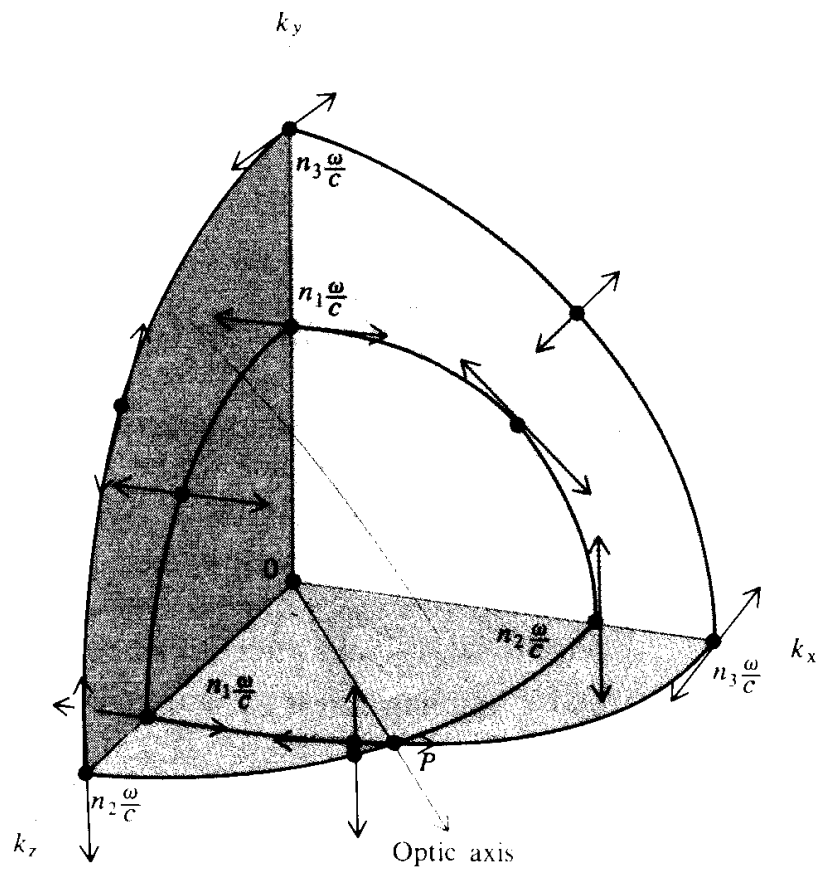

Figure 7: Wave-vector surface for an anisotropic crystal

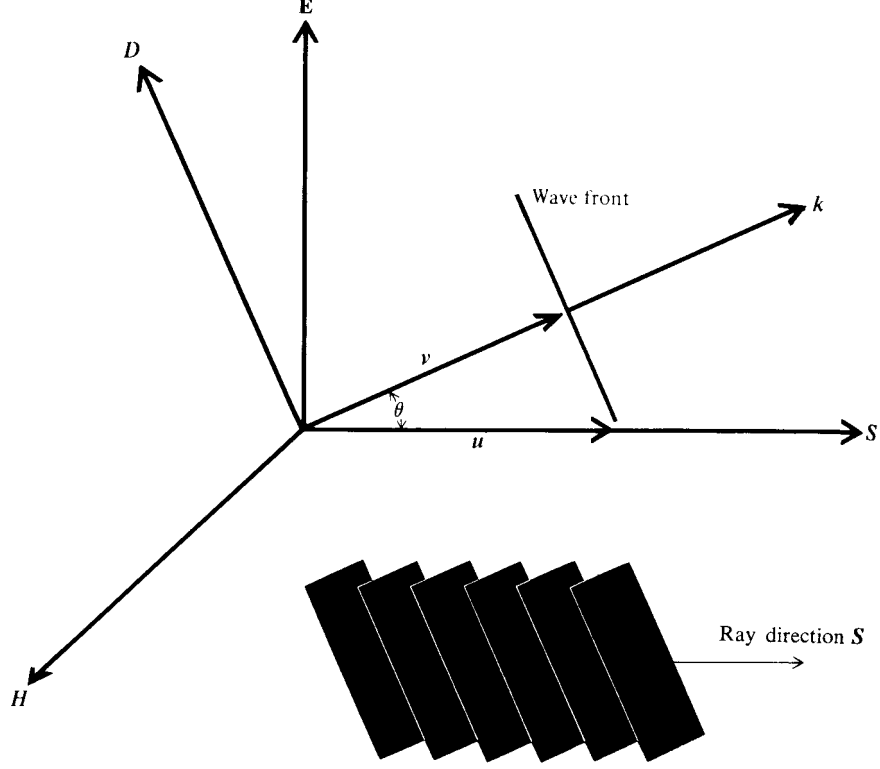

Figure 8: Walk off. Poynting's vector and k are no longer collinear

$$k_x^2 + k_y^2 = \left(\frac{n_3\omega}{c}\right)^2 \quad (34)$$

$$\frac{k_x^2}{(n_2\omega/c)^2} + \frac{k_y^2}{(n_1\omega/c)^2} = 1 \quad (35)$$

which can be seen as the equation of a circle and an ellipse respectively. For a *uniaxial* crystal $n_1 = n_2 \neq n_3$ while for *biaxial* crystal all principal indices are different.

Recognising that $\mathbf{k} = \mathbf{v}(\omega/v^2)$ we can derive the corresponding determinant equation and construct the phase-velocity surface. Finally we can consider the ray-velocity defined by considering the propagation of a narrow beam of light in the crystal. The surfaces of constant phase with velocity u given by

$$u = \frac{v}{\cos \theta} \quad (36)$$

where θ represents the angle between Poynting vector \mathbf{S} (which gives energy flow) and the \mathbf{k} -vector. When we come to discussing harmonic frequency generation in crystals this effect will be referred to as *walk off*.

References

Lasers and Electro-optics C.C. Davis (CUP) chapters 18, 19 20 & 21

[1] *Quantum Electronics* A. Yariv (Wiley) chapters 14, & 16 (3rd edition)

[2] *Fundamentals of Photonics* B.E.A. Saleh & M.C. Teich (Wiley) chapters 18, 19 & 20

[3] *Fundamentals of Nonlinear Optics* P.E. Powers (CRC Press 2011) chapters 2 & 3

[4] *Introduction to Nonlinear Optics* G. New (Cambridge 2011) chapters 2,3 &4

[5] *Optics* E. Hecht (Addison-Wesley) chapter 8 (2nd edition)

[6] *Introduction to Modern Optics* G.R.Fowles chapter 6 (optics of solids)